



Date : 28 October 2024
Our Ref. : PPCL/PLG/10156/L006

Town Planning Board Secretariat,
Town Planning Board,
15/F, North Point Government Offices,
333 Java Road, North Point,
Hong Kong

Attention: The Secretary of the Town Planning Board

By Email

Dear Sir/Madam,

Section 16 Application for Temporary Animal Boarding Establishment for a Period of 5 Years and Filling of Land at Lot 1185 S.E RP in D.D. 106, Kam Tin South, Yuen Long (Planning Application No. A/YL-KTS/1009)

Submission of Further Information 2

Reference is made to the captioned application, which was submitted to the Town Planning Board (“**the Board**”) on 16.7.2024.

To address departmental comments received on 29.8.2024, we herewith submit, on behalf of the Applicant, Further Information 2 (“**FI2**”) in support of the captioned application, for the consideration of the Board. The enclosed materials in the current submission include a Responses-to-Comments Table and a Revised Traffic Run-in/out Proposal.

The above submission does not result in a material change of the nature of the captioned application.

Should you have any queries, please do not hesitate to contact the undersigned [REDACTED]. Thank you for your kind attention.

Yours faithfully,
For and on behalf of
PlanPlus Consultancy Limited

Derek Li
Assistant Town Planner

Encl. As above
c.c. Mr. Pang Yiu Fai, Christopher (Town Plnr/Yuen Long E 5)
Mr. Mo Ying Yeung (Town Planning Grad/Fanling, Sheung Shui & Yuen Long E 1)
The Applicant



**Section 16 Application for
Proposed Temporary Animal Boarding Establishment
for a Period of 5 Years and Filling of Land
at Lot 1185 S.E RP in D.D. 106,
Kam Tin South, Yuen Long, New Territories**

Planning Application No. A/YL-KTS/1009

Further Information 2

Prepared by : PlanPlus Consultancy Limited

October 2024

Reference : PPC-PLG-10156

Responses-to-Comments

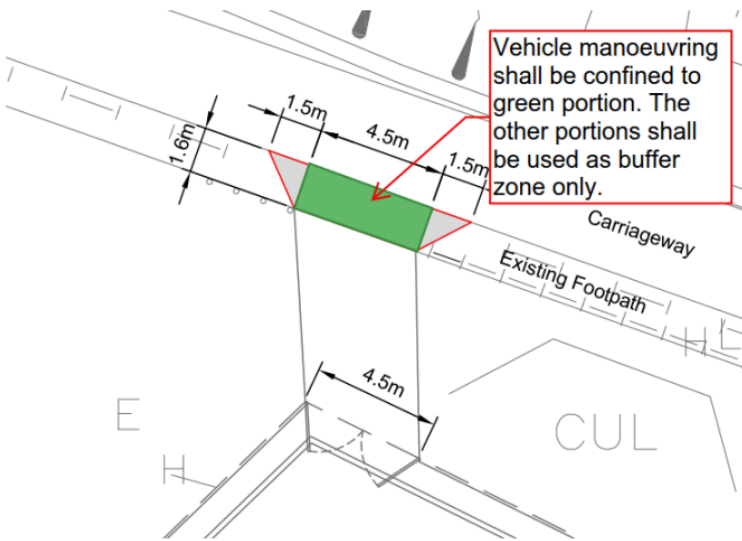
Item	Departmental Comments	Applicant's Responses
1. Comments from the Transport Department		
1.	<p>I reiterate that the proposed run-in/out shall be designed wide enough for 7m LGV manoeuvring. More specifically, vehicles manoeuvring on the kerb on slope shall be avoided as much as practicable. I attach an illustrative figure below. The applicant shall review the size of run-in / out accordingly.</p> 	<p>Noted. Attached please find the revised figures of the Run-in/out Proposal, which demonstrate a widened run-in/out to cater for the manoeuvring of 7m LGV.</p> <p>Moreover, the run in/out shall be properly managed as it is for internal use only. We shall limit our LGV turning from the access of Application Site to Kam Shui South Road westbound only, which could ensure a smooth manoeuvring.</p>

October 2024

PlanPlus Consultancy Limited

Ref: PPCL-PLG-10156

X:\Ozzo\82685 S16 for Proposed Temporary Animal Boarding Establishment at Lot 1185 SE RP in DD 106 and Adjoining Government Land, Kam Tin South, Yuen Long

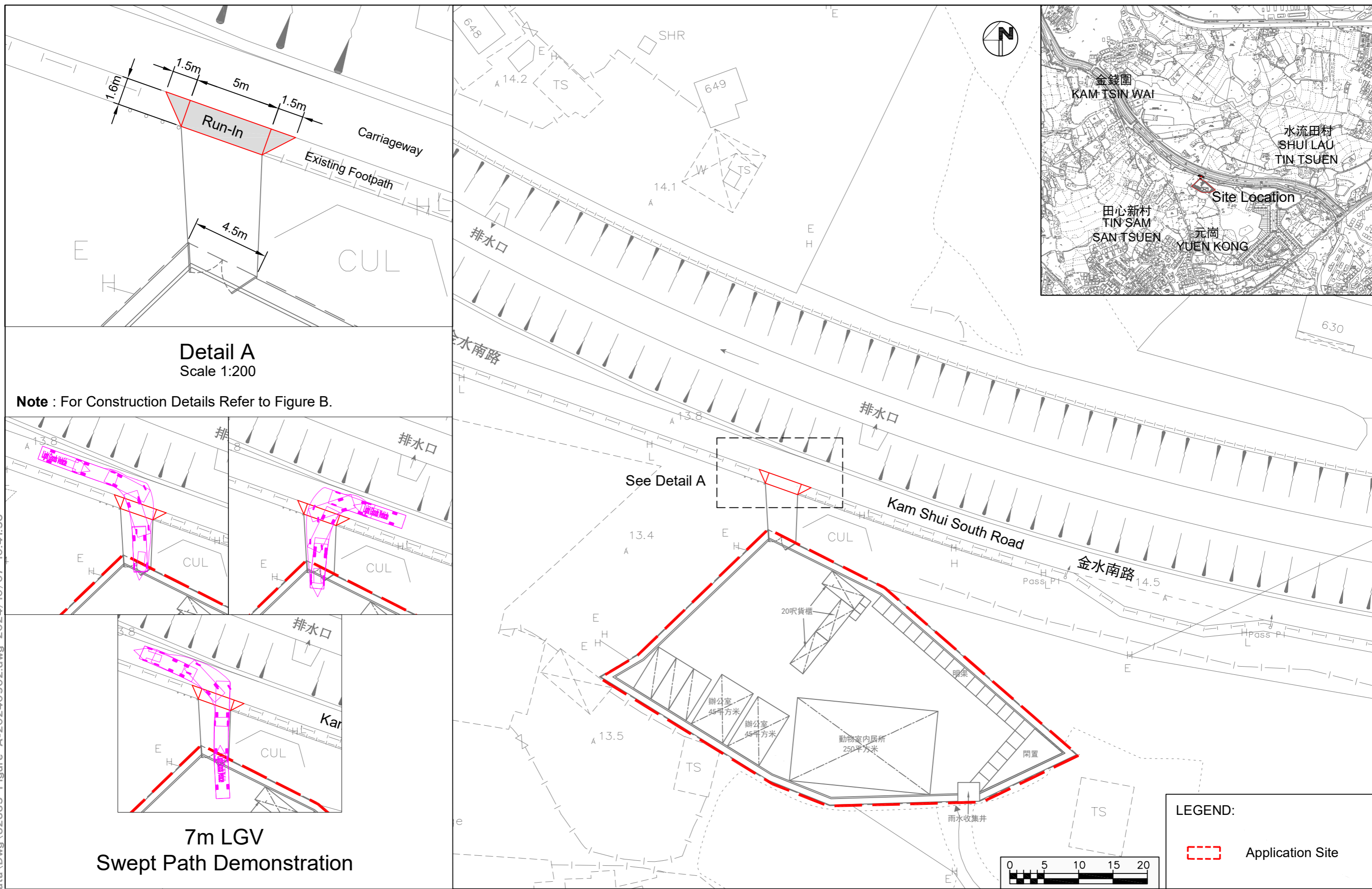

Detail A
Scale 1:200

Note : For Construction Details Refer to Figure B.

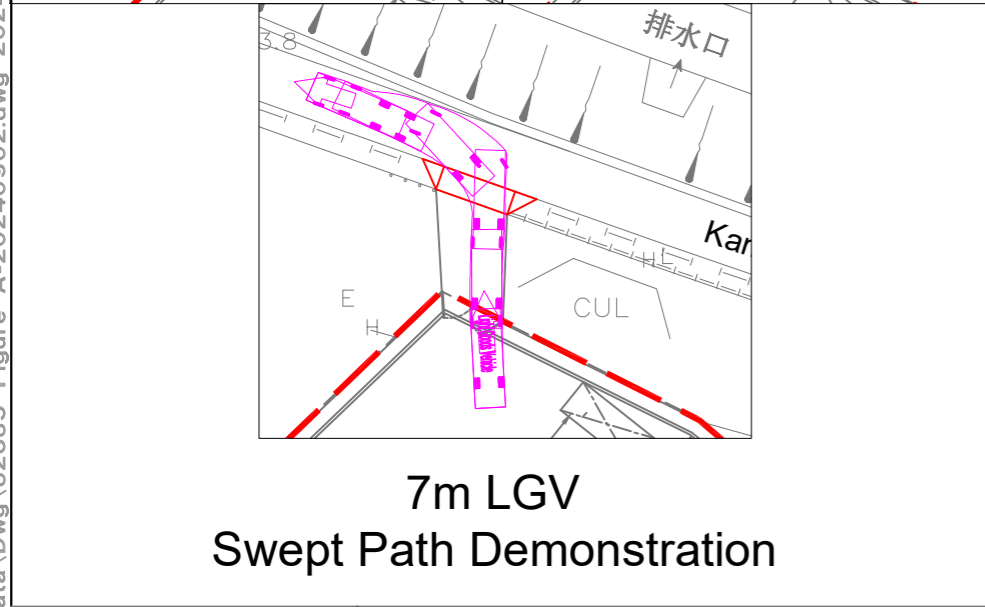
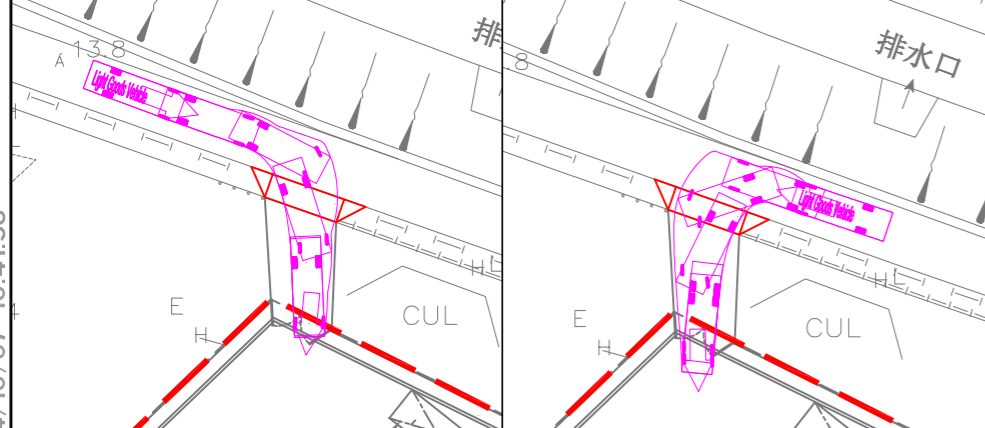

LEGEND:

Application Site

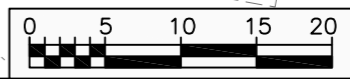

Date	02/09/2024
Scale	1:500

Project Title S16 for Proposed Temporary Animal Boarding Establishment at Lot 1185 SE RP in DD 106 and Adjoining Government Land, Kam Tin South, Yuen Long	
Proposed Run In /Out at Kam Shui South Road	

Project No.	82685
Dwg No.	Figure A
Rev.	2

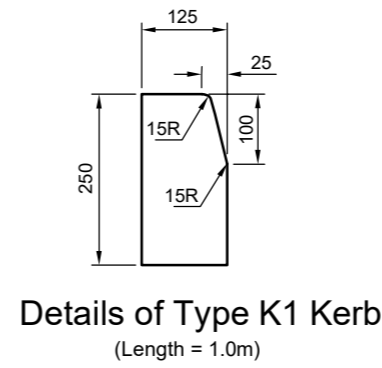
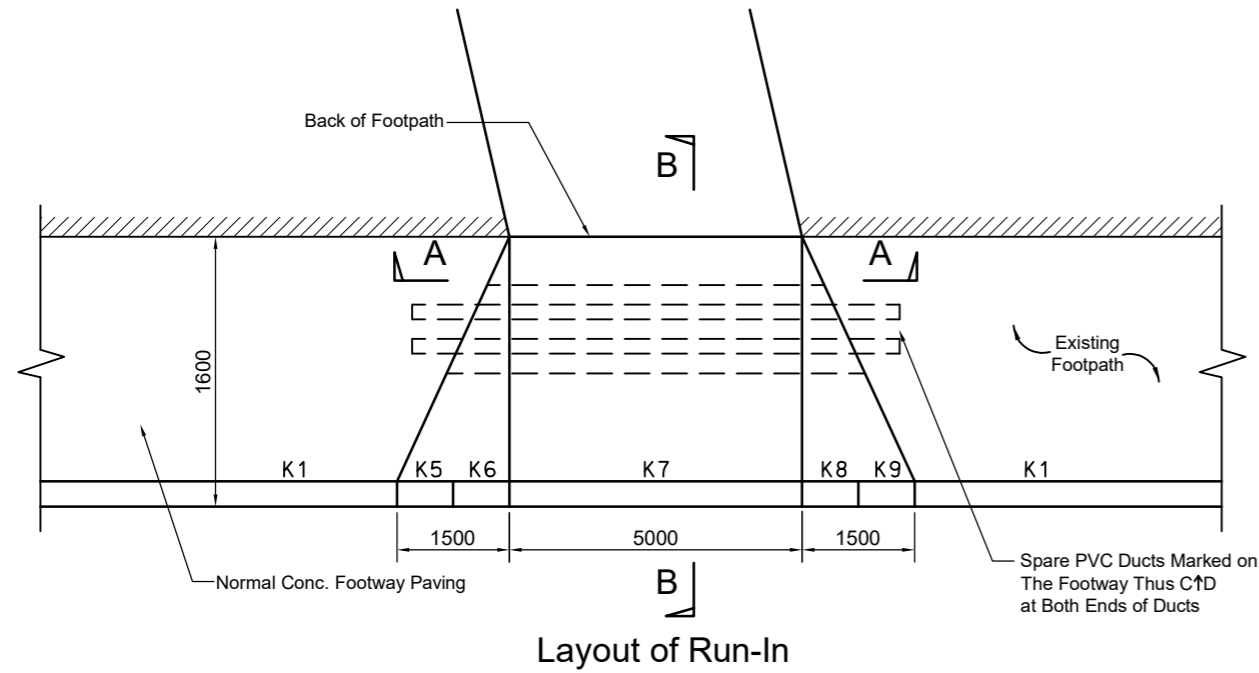

Notes :

1. The Nominal Length of a Kerb Unit Shall be 1000mm and an Edging Unit 750.
2. Concrete Shall be Grade 30/20.
3. Precast Concrete Kerbs Edgings and Quadrants Shall Comply with B.S. 7263 Part 1 Except That The Requirement for Testing of Water Absorption Shall Not be Applied.
4. All Dimensions are In Millimetres.

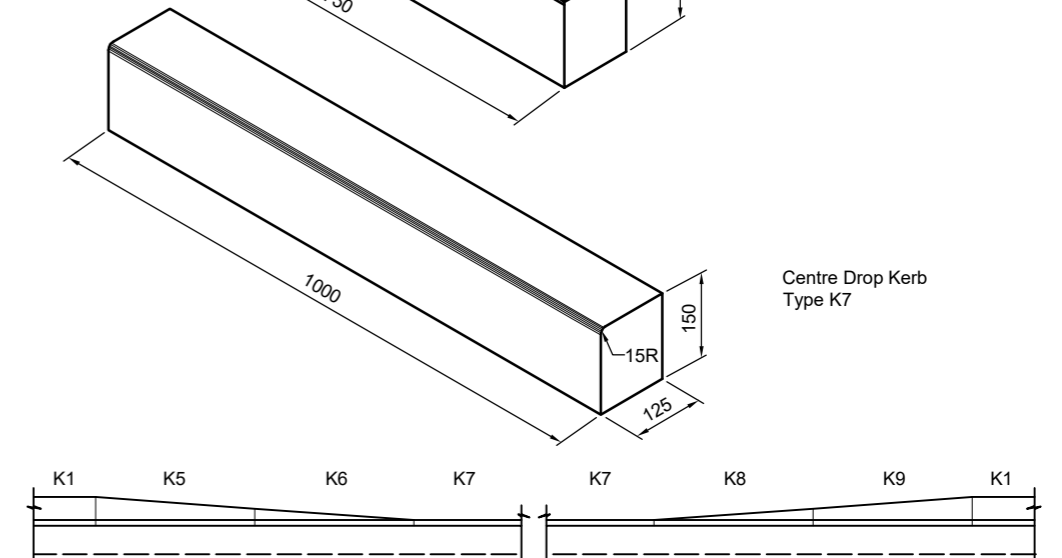
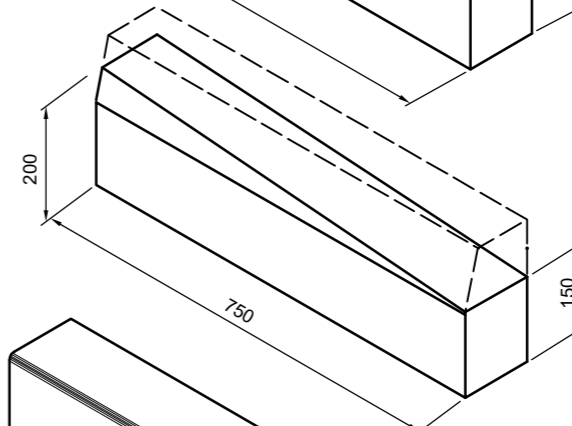
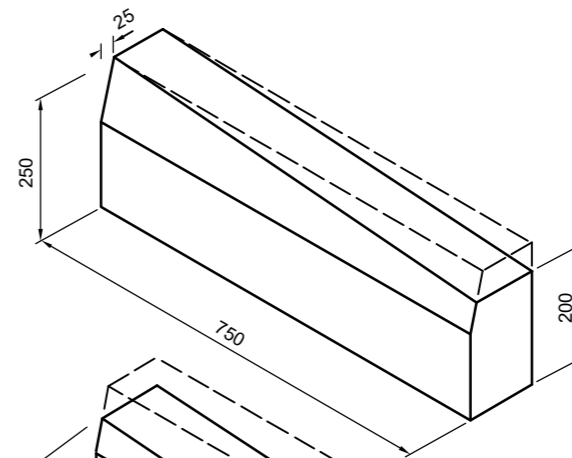

Details and Layout of Kerb
K1, K5, K6, K7, K8 and K9

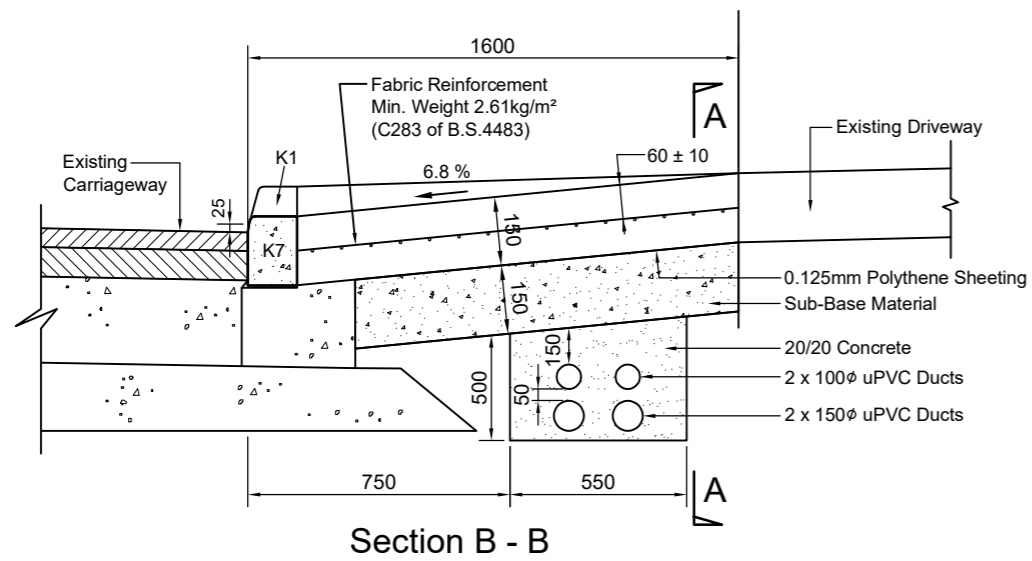
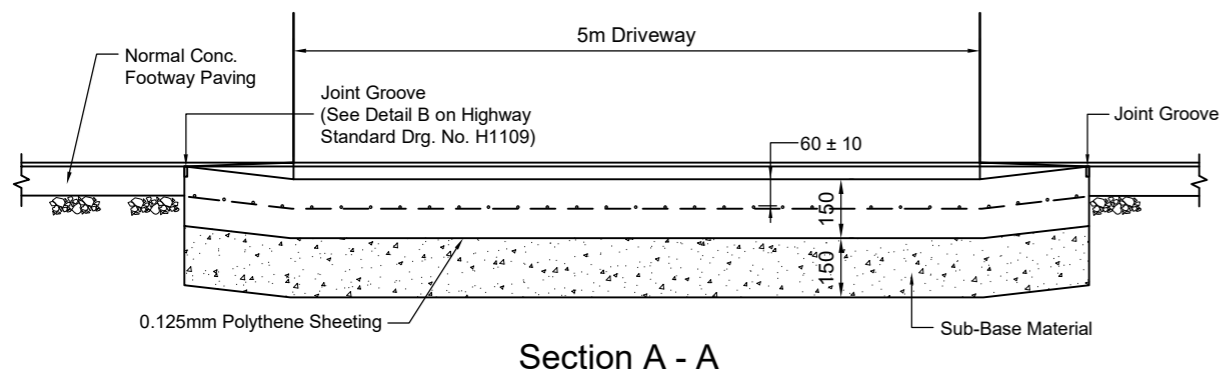

S16 for Proposed Temporary Animal Boarding Establishment at Lot 1185 SE RP in DD 106 and Adjoining Government Land, Kam Tin South, Yuen Long

Details of Run-In



Project No.	82685	Rev.	
Dwg No.	Figure B		2



Date	05/09/2024	Scale	N.T.S.
------	------------	-------	--------